

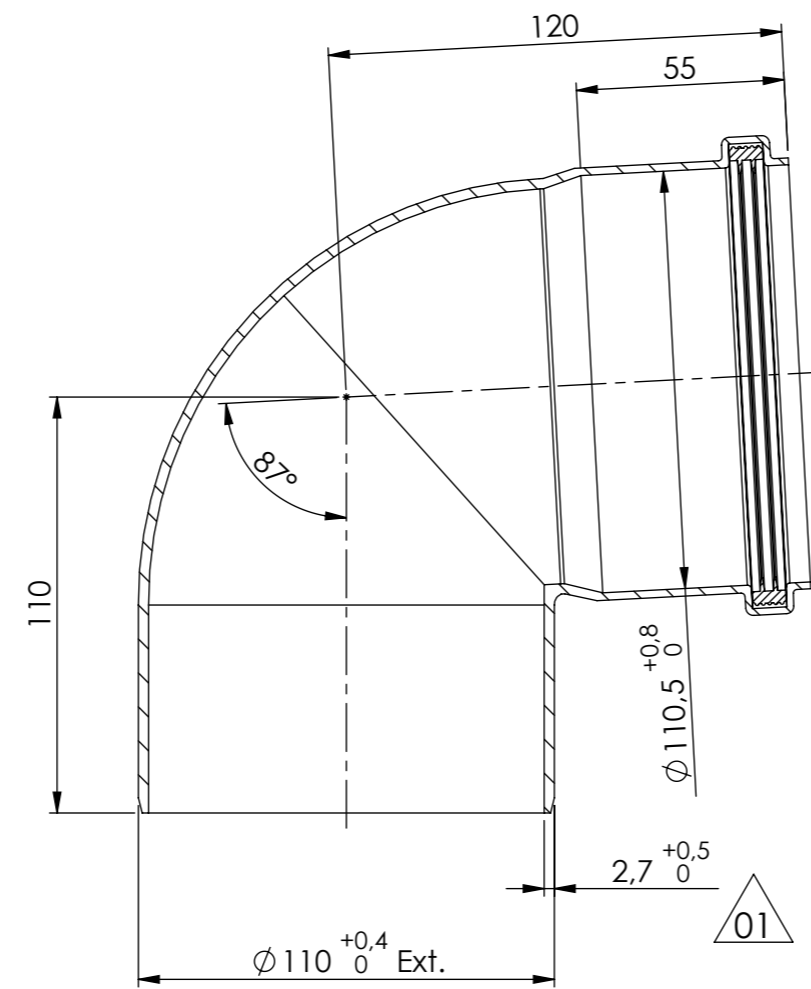

This drawing is property of Cox Geelen and may not be copied in whole or in part without the prior written consent of the owner

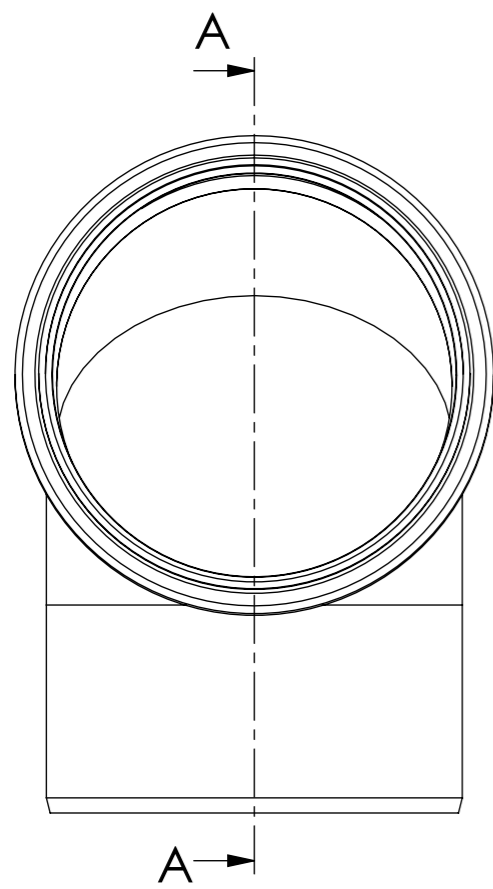

SECTION A-A

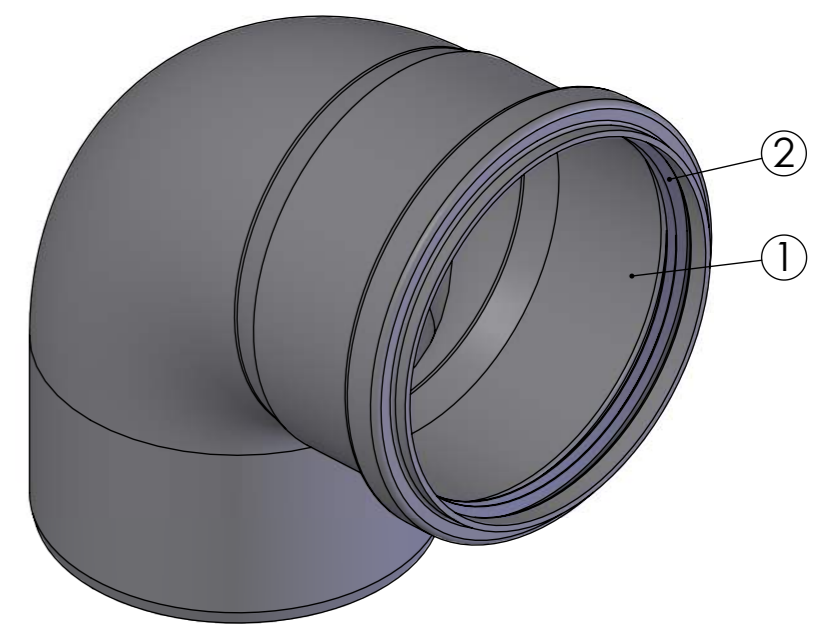

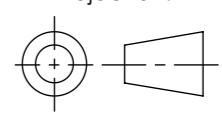
2	1	Seal $\varnothing 110$	EPDM Flue gas	L0295	891198			
1	1	Bend $\varnothing 110$ 87°	PPs	-	-			
Pos.	QTY.	Description	Material	Drawing	Part nr			
Unit of measure:		mm	Name:	R. Houwen	Date:	10-04-2012	Material:	-
Scale:		1:2	Checked:	L. Goessen	Date:	10-04-2012	Mass[g]:	178.90
Title:							Comments:	
PPs bend $\varnothing 110$							Old drawing L0020/07102	
CAD Model: PPs bocht 110 87							Part.no: CKAH	
Configuration: Default								
 <b>Cox Geelen</b> www.coxgeelen.com			Tolerances: $\varnothing = \pm 0.5$ $L = \pm 3$ $< = \pm 3^\circ$		Projection: 		Dwg. no. : <b>A1873P01</b>   A3	

Revisions					
01	Tolerance added	16001	12-01-2016	RoHo	
00	Production drawing	12001	10-04-2012	RoHo	