

This drawing is property of Cox Geelen and may not be copied in whole or in part without the prior written consent of the owner

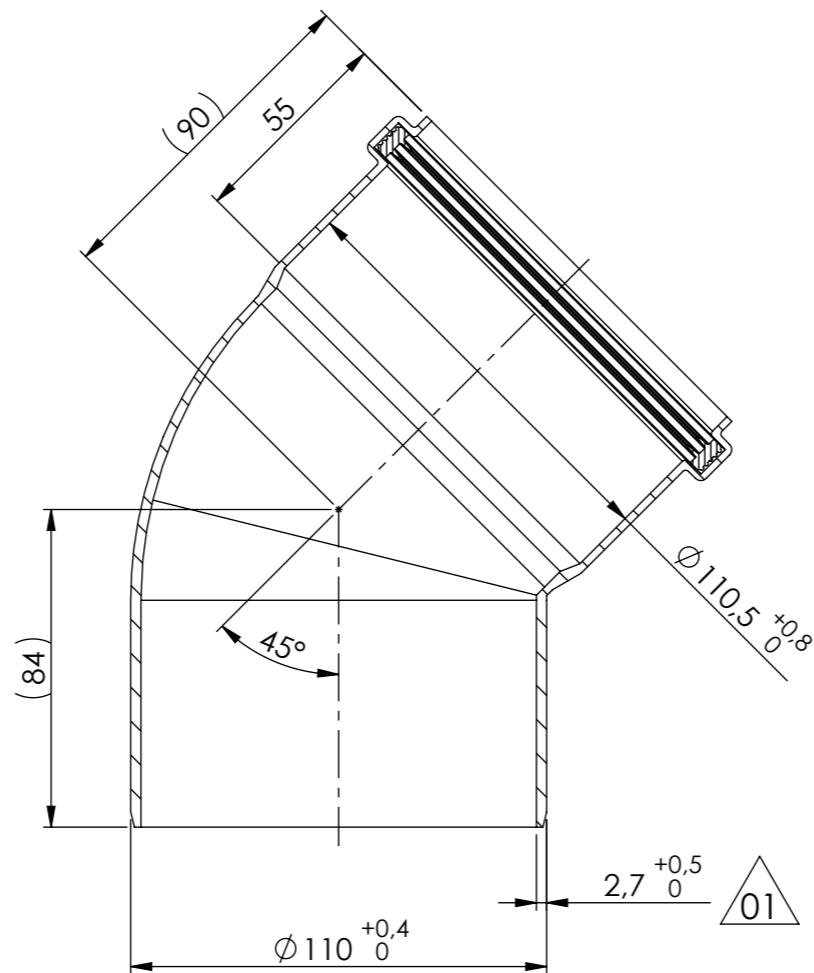

SECTION A-A

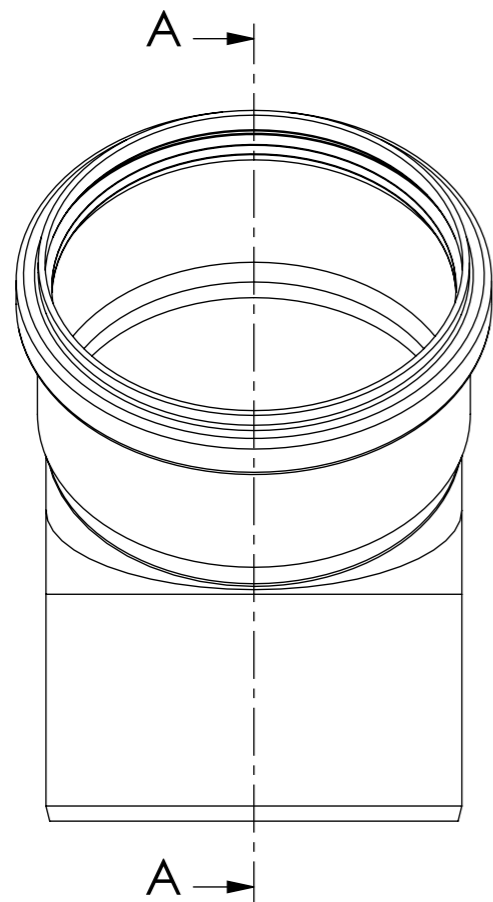
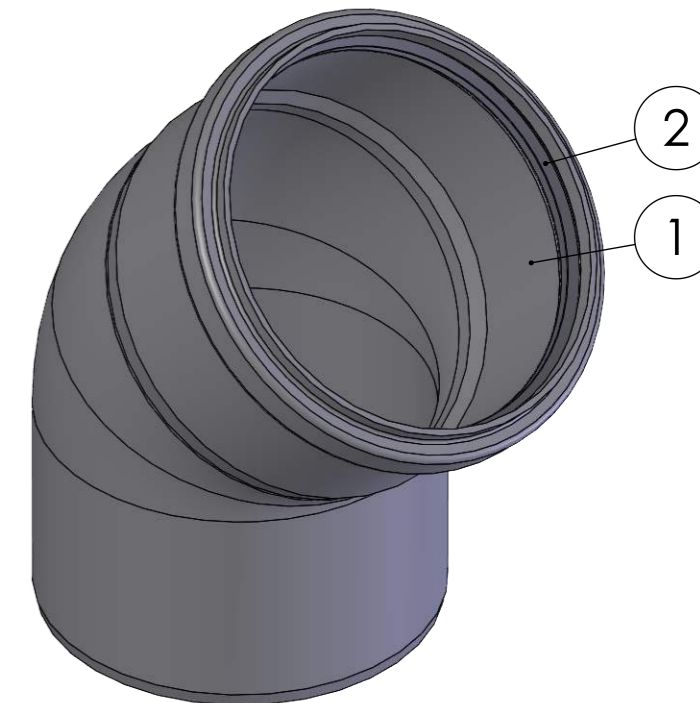

2	1	Seal $\varnothing 110$	EPDM Flue gas	0136143	891198
1	1	Flue bend $\varnothing 110$ 45°	PPs	-	-
Pos.	QTY.	Description	Material	Drawing	Part nr

Scale: 1:2 Unit of measure: mm Material: - Comments:
 Title: Flue bend $\varnothing 110$ 45° PPs Old drawing: L0017

CAD Model: 3D0163074 Configuration: Default A1874 A

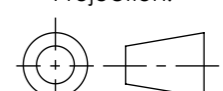
 Cox Geelen www.coxgeelen.com	Tolerances: $\varnothing = \pm 0.5$ $L = \pm 3$ $< = \pm 3^\circ$	Projection: 
	Dwg. no. : 0135117P01 A3	

01	Tolerance added	16001	12-01-2016	RoHo	LuGo
00	Production drawing	12001	10-04-2012	RoHo	LuGo
Rev.	Description	Project nr.	Date	Created	Checked