

This drawing is property of Cox Geelen and may not be copied in whole or in part without the prior written consent of the owner

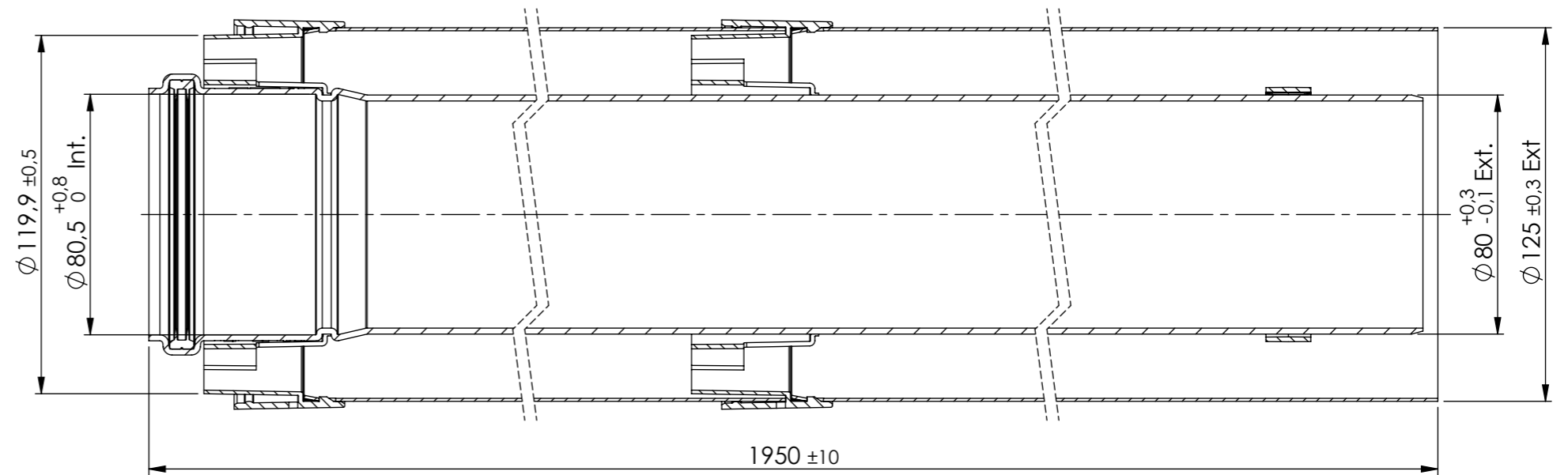
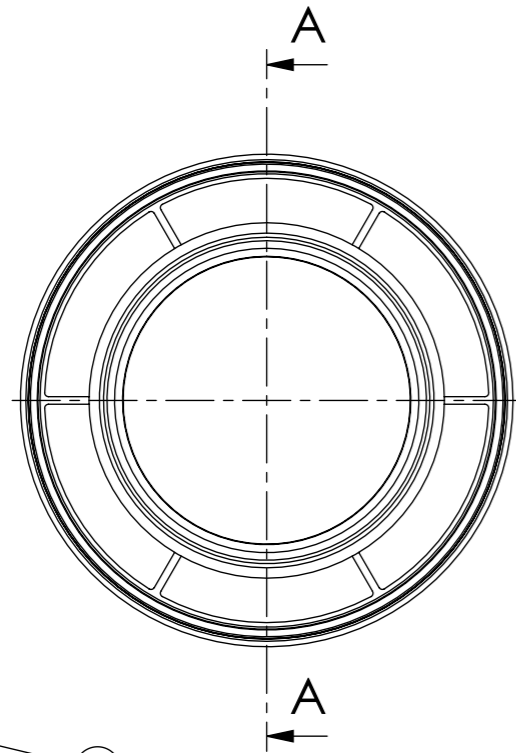
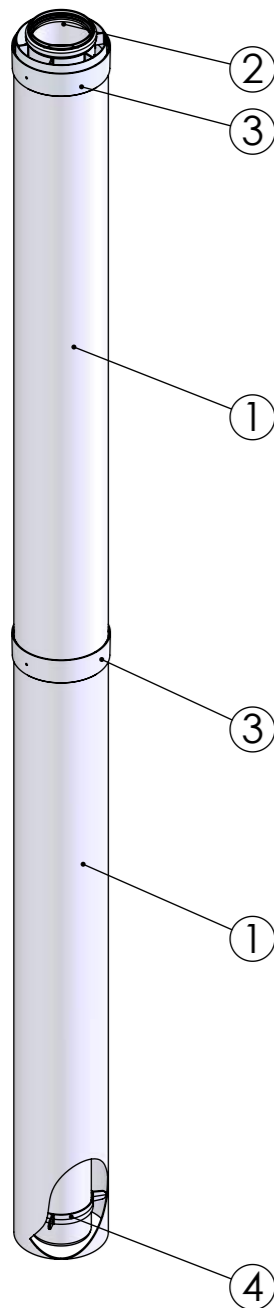

SECTION A-A

Pos.	QTY.	Description	Material	Drawing	Part nr
4	1	Distance ring ø80-125	PP	A0013	891598
3	2	Coupling unit ø80-125	PC/ABS	A0067	-
2	1	Flue Pipe ø80 Extrusion	-	L0697	BLAAAK600
1	2	Air-inlet pipe ø125	EN-AW-1050A	08127	703295

Scale: 1:2 Unit of measure: mm Material:

Title: **Pipe ø80-125 L1950 PP-AI Connex**

Comments: Thickness of coating: average ≥70µm

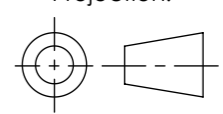
 Cox Geelen www.coxgeelen.com	Tolerances: $\varnothing = \pm 0,5$ $L = \pm 3$ $< = \pm 3^\circ$	Projection: 	Dwg. no. : B0034 P00 A3
	CAD Model: Pipe 80-125 L1950 PP-AI coupling Configuration: 80-125 L1950		

00	Production drawing	13020	09-05-2016	F. Knoops	C. Vaessen
	Revisions			Created	Checked