

This drawing is property of Cox Geelen and may not be copied in whole or in part without the prior written consent of the owner

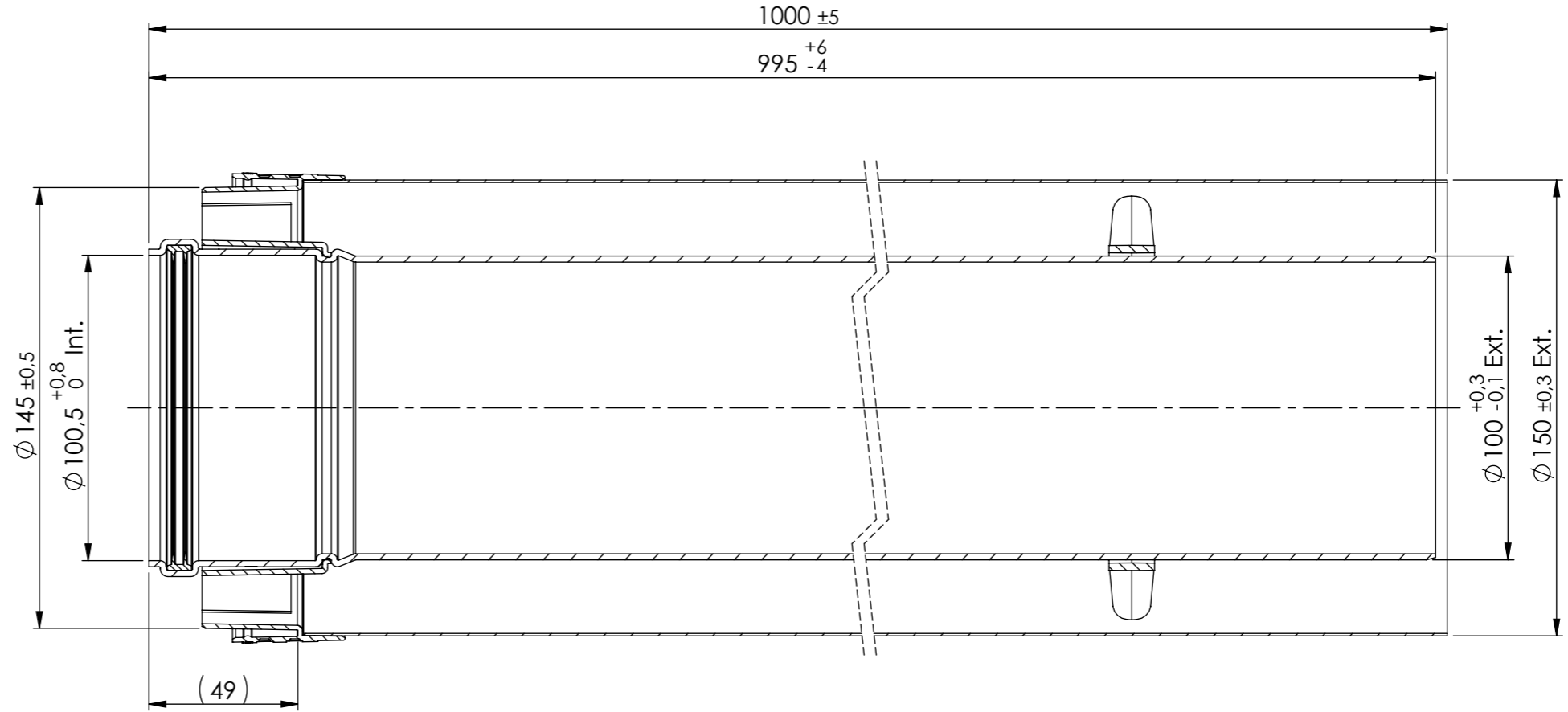
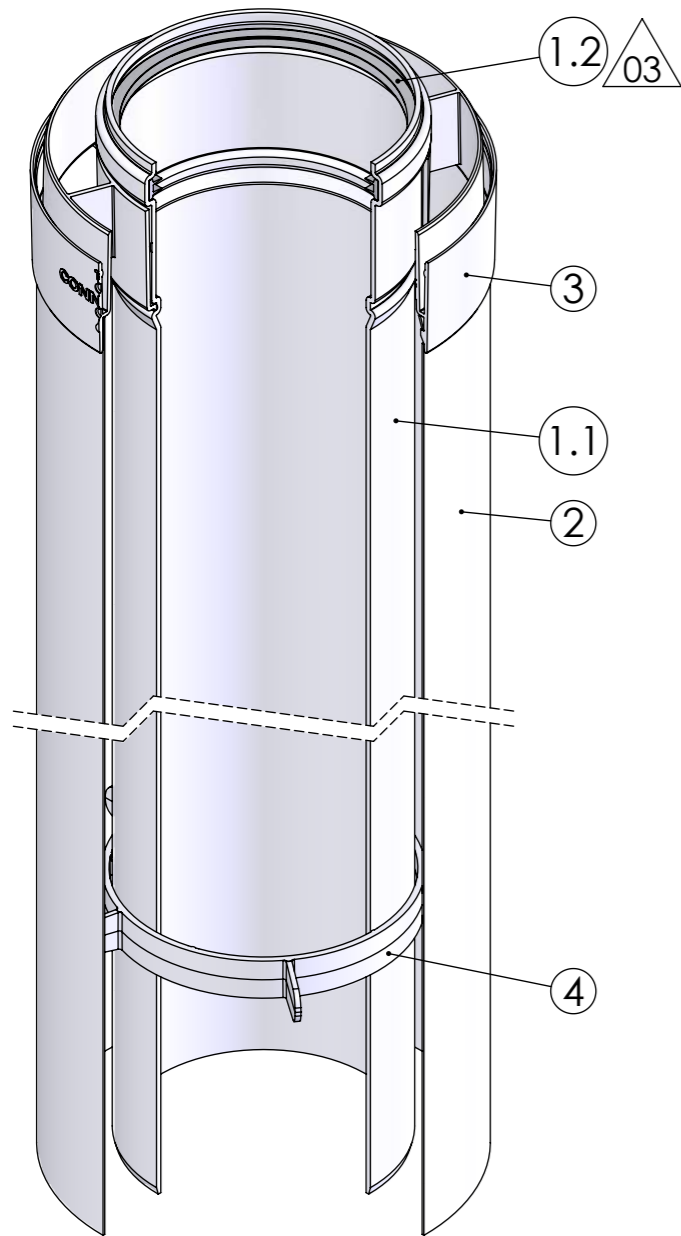

Pos.	QTY.	Description	Material	Drawing	Part nr
4	1	Concentric bracing bracket ø100-150	CoxPP-AZA	L0685	891218
3	1	Coupling unit ø100-150	ABS	A2255	-
2	1	Air pipe ø150 L948	EN-AW-1050A	A2270	-
1.2	1	Seal EPDM Flue gas ø100 S	EPDM Flue gas	A1960	891311
1.1	1	Flue pipe ø100 L995	CoxPP	A2241	-
1	1	Flue pipe ø100	-	A2290	CLAAAK600

Scale: 1:2 Unit of measure: mm Material: - Comments: Thickness of coating: average ≥70µm

Title: Concentric pipe ø100-150 L1000 PP-Al coupling

CAD Model: Pipe D100-150 PP-Al coupling
Configuration: Lnom.1000 - section

Revisions	Created	Checked
03 Seal color changed	17006 24-10-2017 M. Ubags E. Franssen	
02 Spring replaced by bracing bracket	16001 01-07-2016 M. Ubags L. Goessen	
01 Dimension changed	16001 15-06-2016 D. Hendrix C. Vaessen	
00 Production drawing	11080 19-11-2013 M. Ubags C. Vaessen	



Tolerances:
 $\phi = \pm 0,5$
 $L = \pm 3$
 $< = \pm 3^\circ$

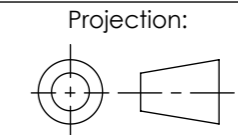

Dwg. no. : **A2320 P03** A3