

This drawing is property of Cox Geelen and may not be copied in whole or in part without the prior written consent of the owner

L1
250
500

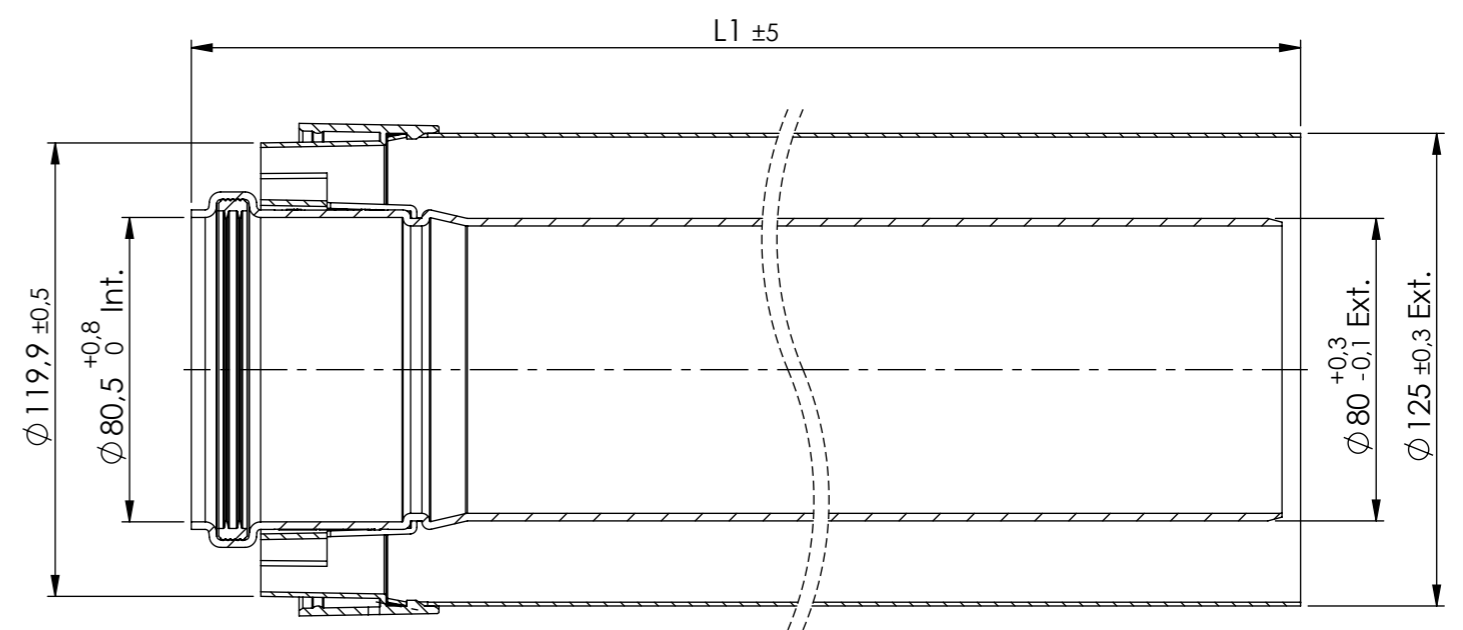

SECTION A-A

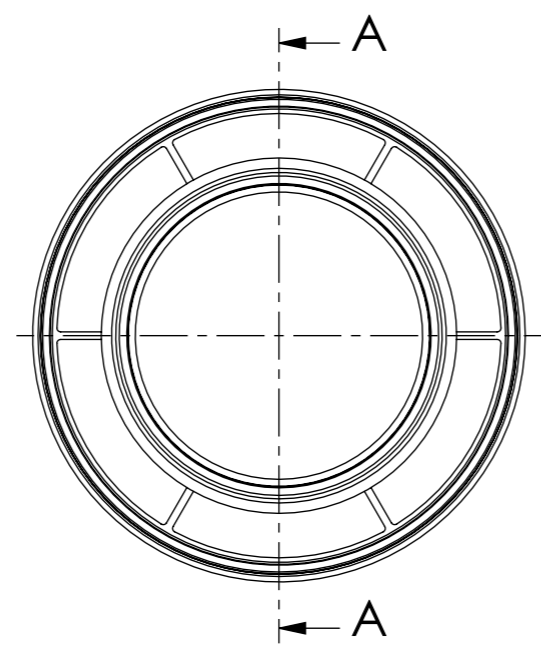
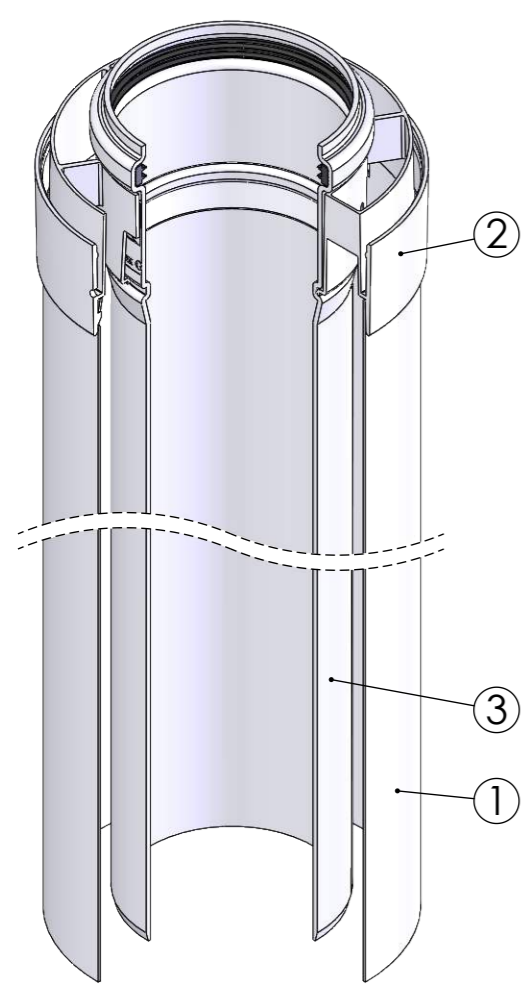

Pos.	QTY.	Description	Material	Drawing	Part nr
3	1	Flue Pipe ø80 Extrusion PP	-	0138176	-
2	1	Coupling unit ø80-125	PC/ABS	0137112	-
1	1	Air-inlet pipe ø125 L448	EN-AW-1050A	08127	703294

Scale: 1:2      Unit of measure: mm      Material: -      Comments: Thickness of coating: average  $\geq 70\mu\text{m}$

Title: **Pipe ø80-125 PP-Al ConneXt**

CAD Model: 3D0165389      Configuration: General drawing (L500)      B0038      B

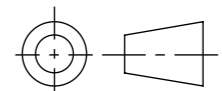
 <b>Cox Geelen</b> www.coxgeelen.com	Tolerances: $\phi = \pm 0,5$ $L = \pm 3$ $\angle = \pm 3^\circ$	Projection: 	Dwg. no. : <b>0137238 P 00</b> A3
--	--	--	-----------------------------------

Rev.	Description	Project nr.	Date	Created	Checked
00	Production drawing	13020	09-05-2016	FrKn	CaVa