

This drawing is property of Cox Geelen and may not be copied in whole or in part without the prior written consent of the owner

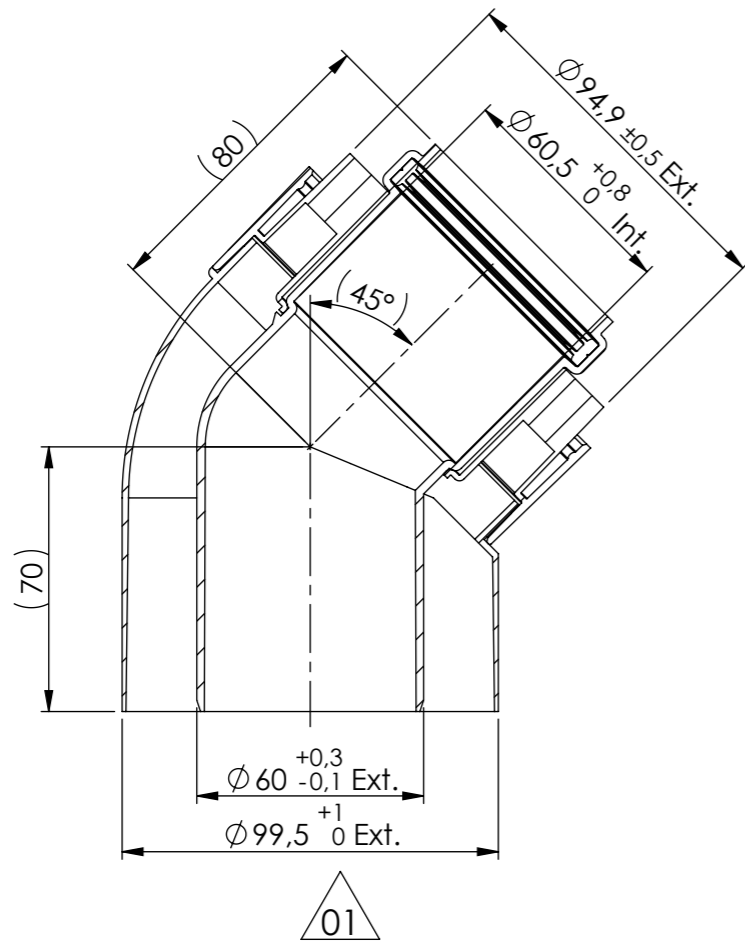
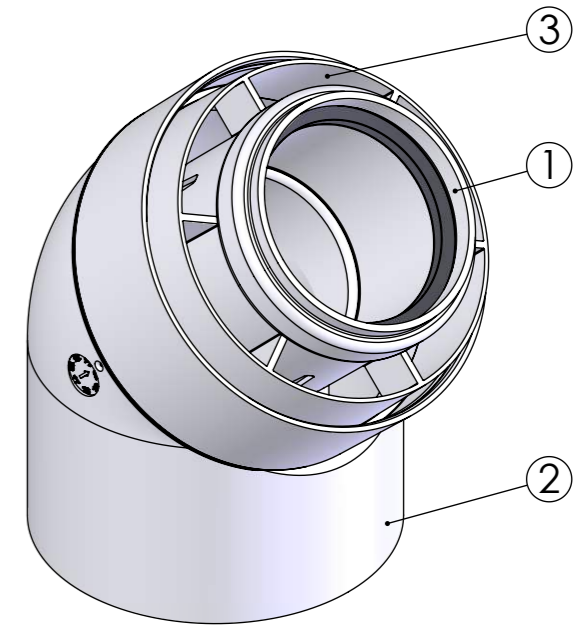
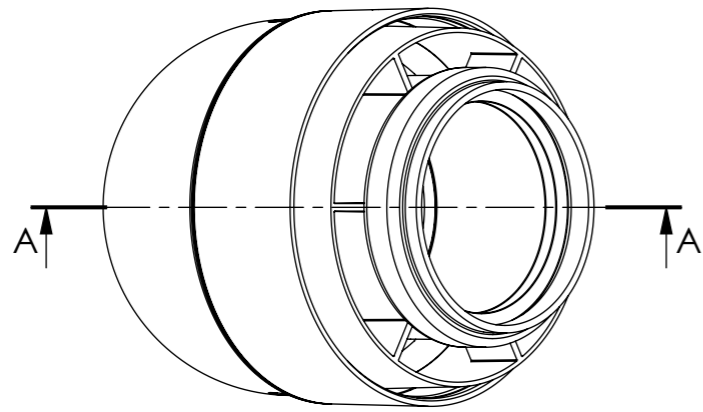

SECTION A-A

01	Tolerance changed	13020	16-12-2020	RoHo	LuGo
00	Production drawing	13020	02-05-2016	FrKn	CaVa
Rev.	Description	Project nr.	Date	Created	Checked

3	1	Coupling unit ø60-100	PC/ABS	0137111	-
2	1	Bend ø100 45° Al coupling	EN-AC-46000	0134052	891701
1	1	Flue Bend ø60 45° PP	-	0138082	ALAJAK600
Pos.	QTY.	Description	Material	Drawing	Part nr

Scale: 1:2 Unit of measure: mm Material: -

Title: Bend ø60-100 45° PP-Al ConneXt

CAD Model: 3D0165334 Configuration: Standard B0027 B



Cox Geelen  
www.coxgeelen.com

Tolerances:  
 $\phi = \pm 0,5$   
 $L = \pm 3$   
 $< = \pm 3^\circ$

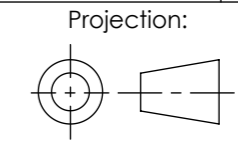

Comments:  
Thickness of coating: average  $\geq 70\mu\text{m}$

Dwg. no. : 0137227 P 01 A3